

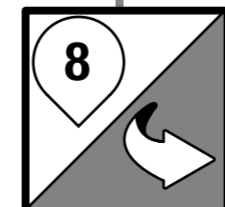

TOEPYEULA5002

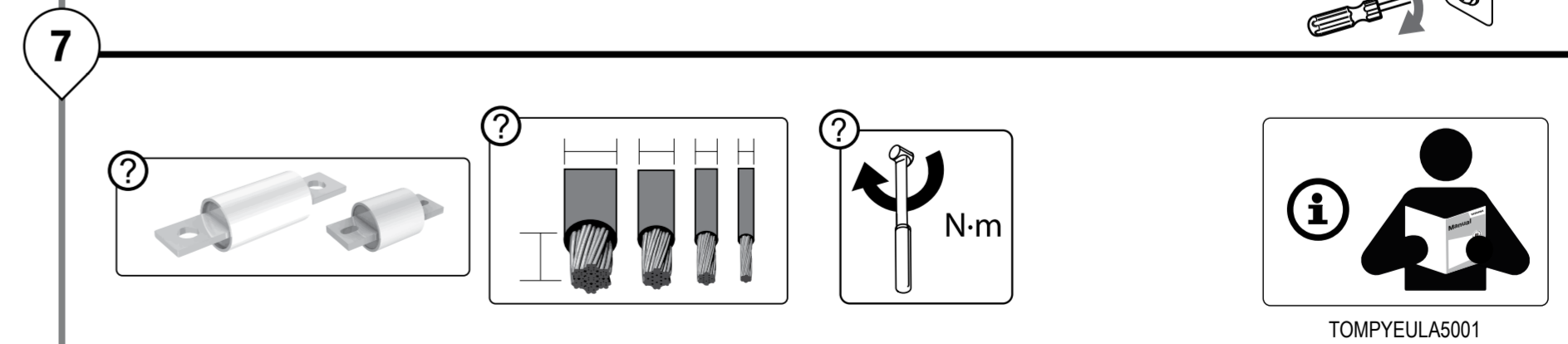

8

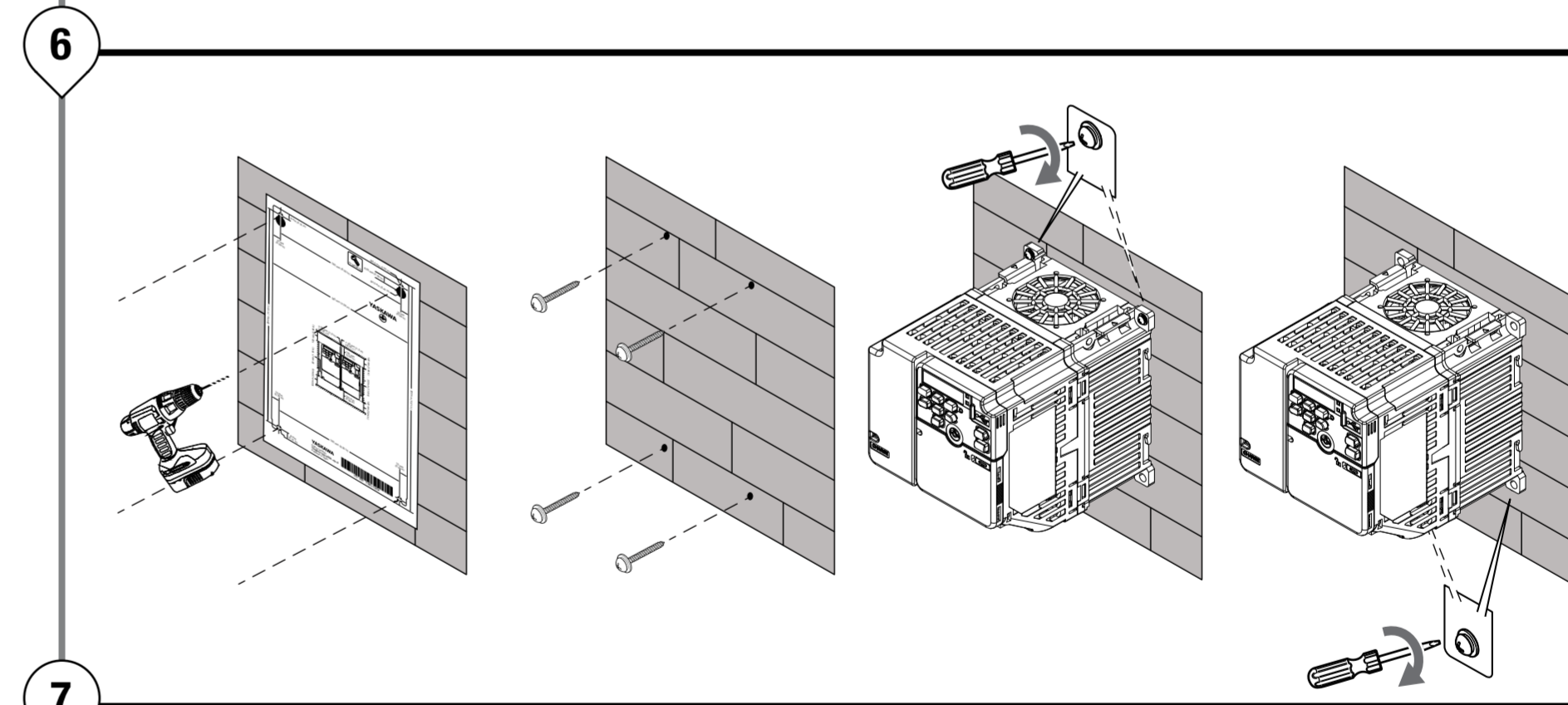
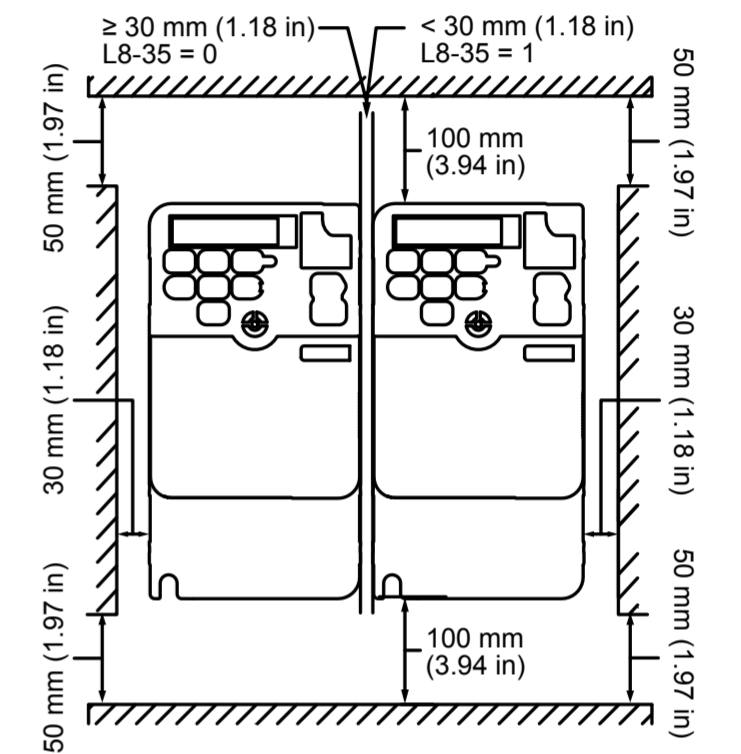
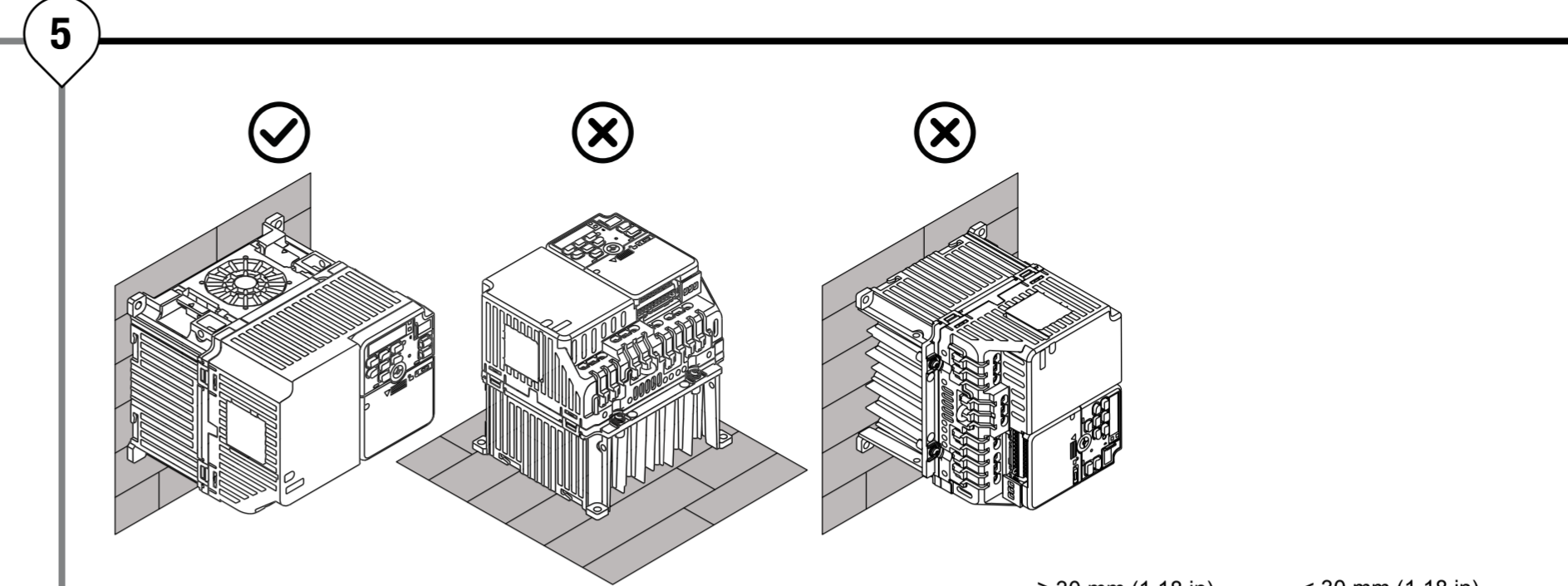
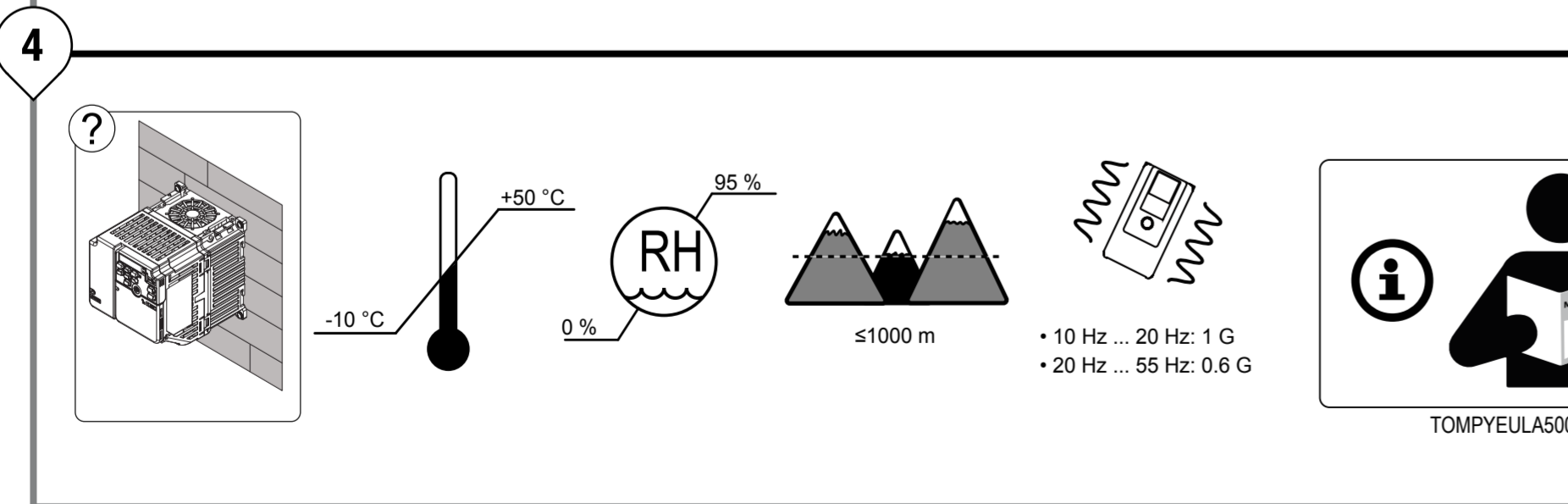
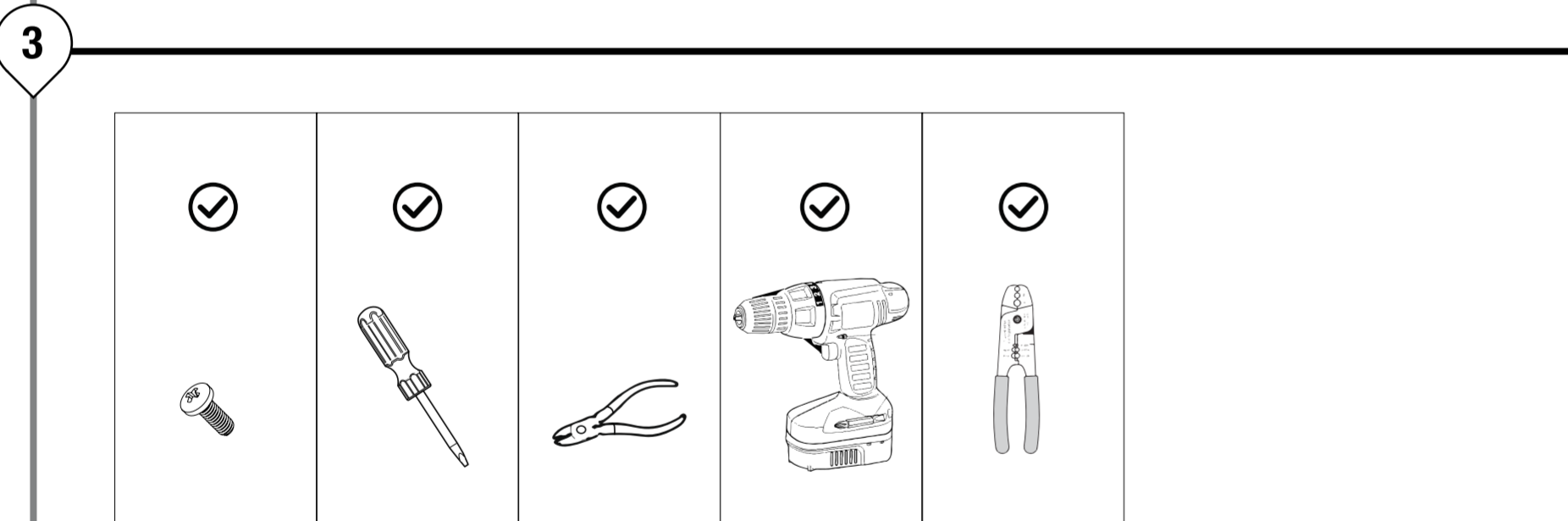
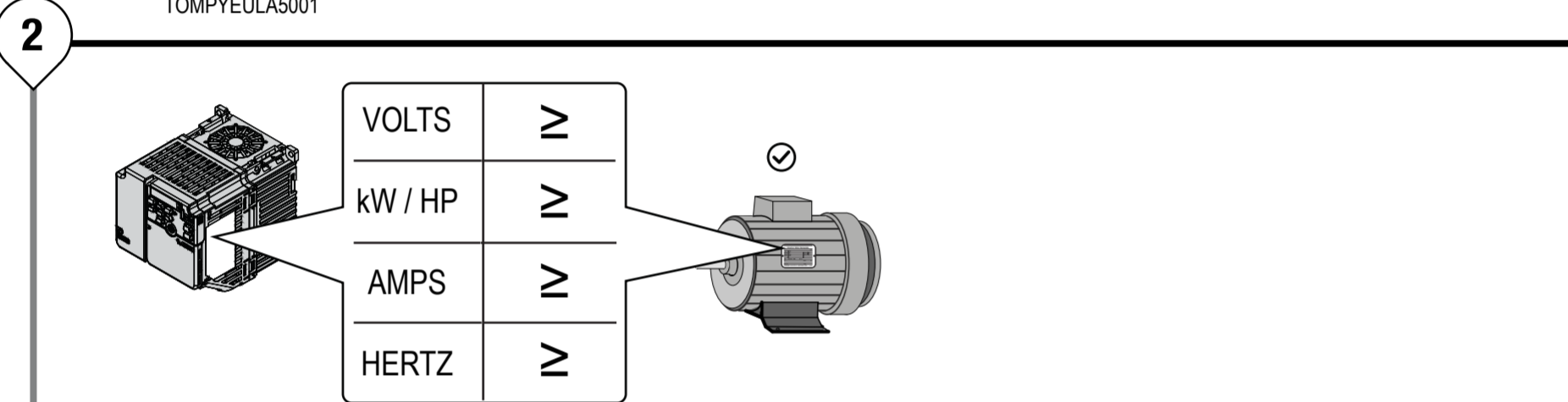
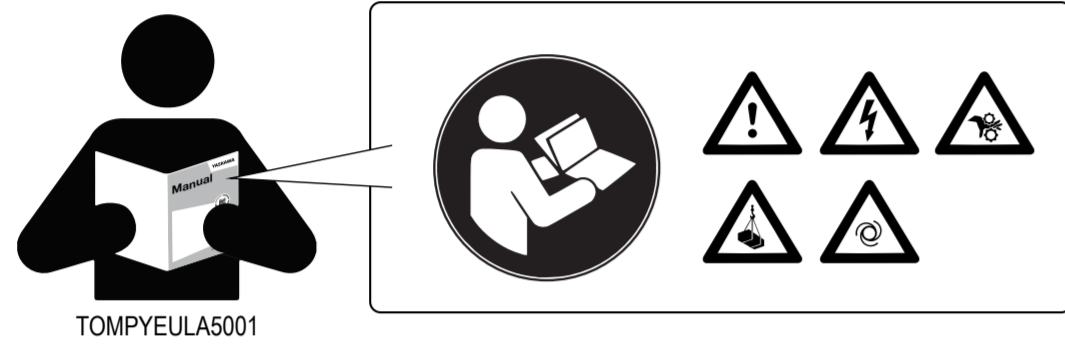
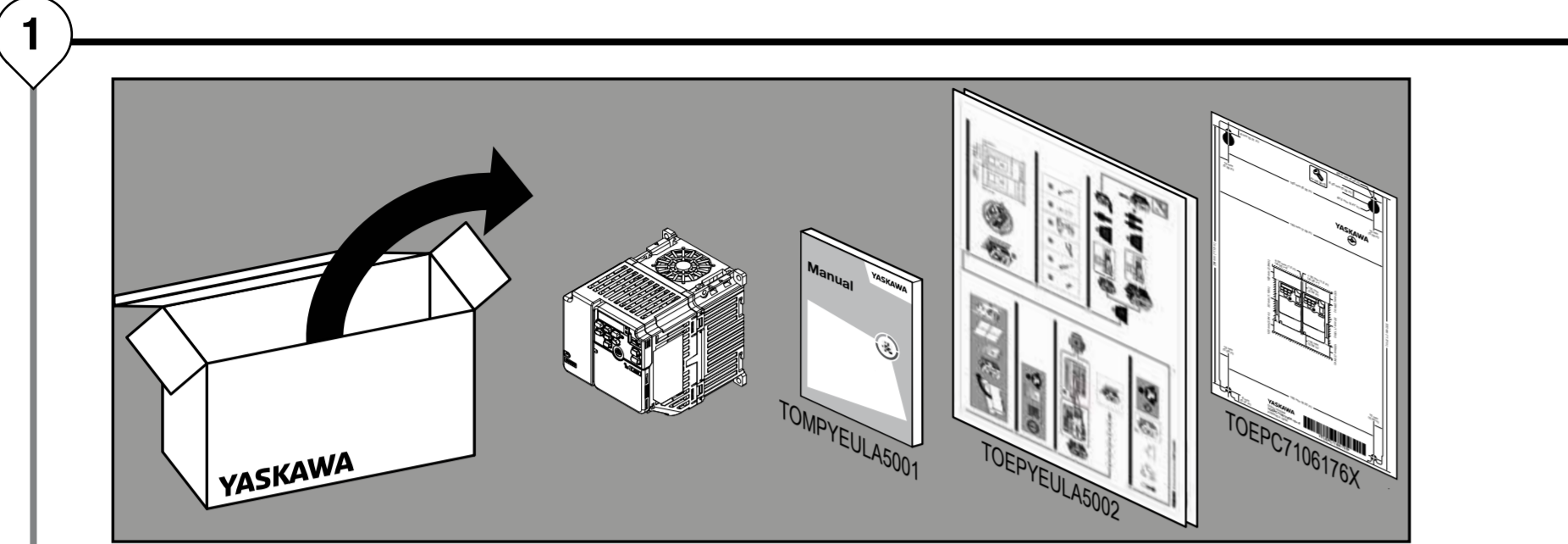
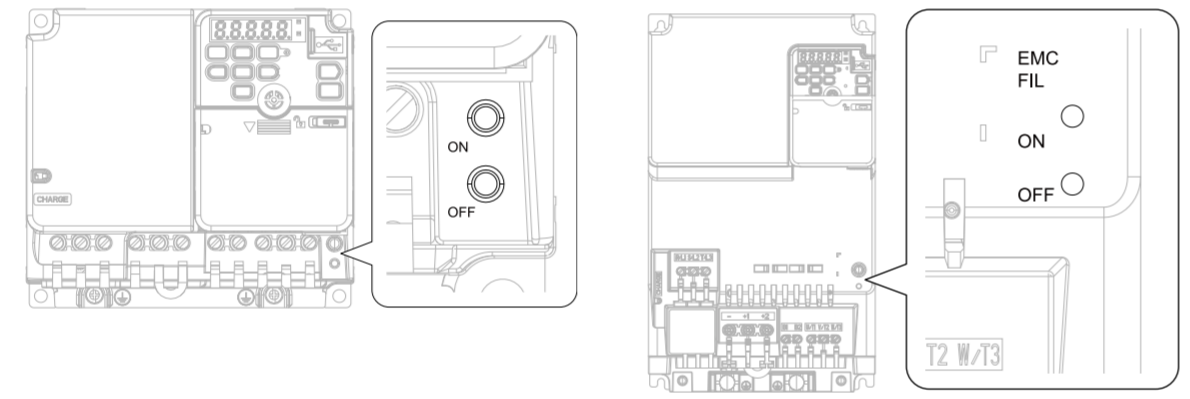
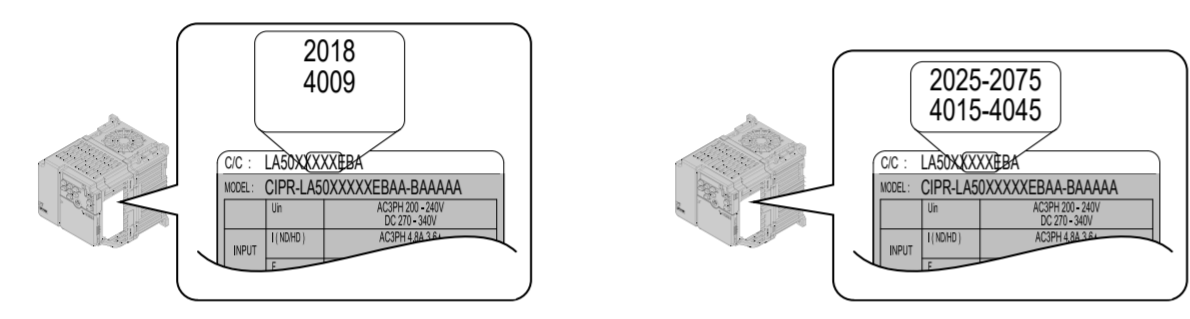
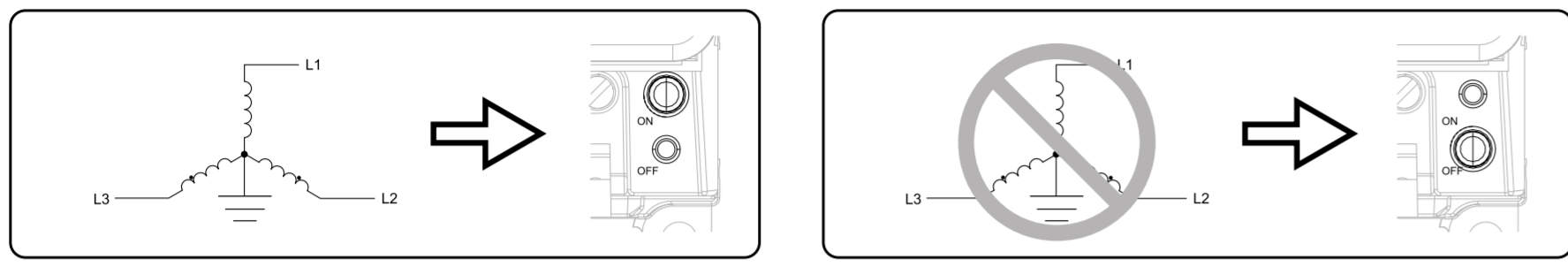
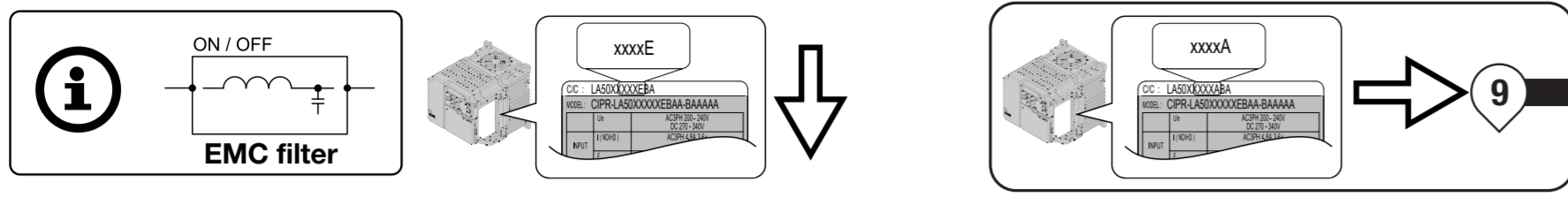

9

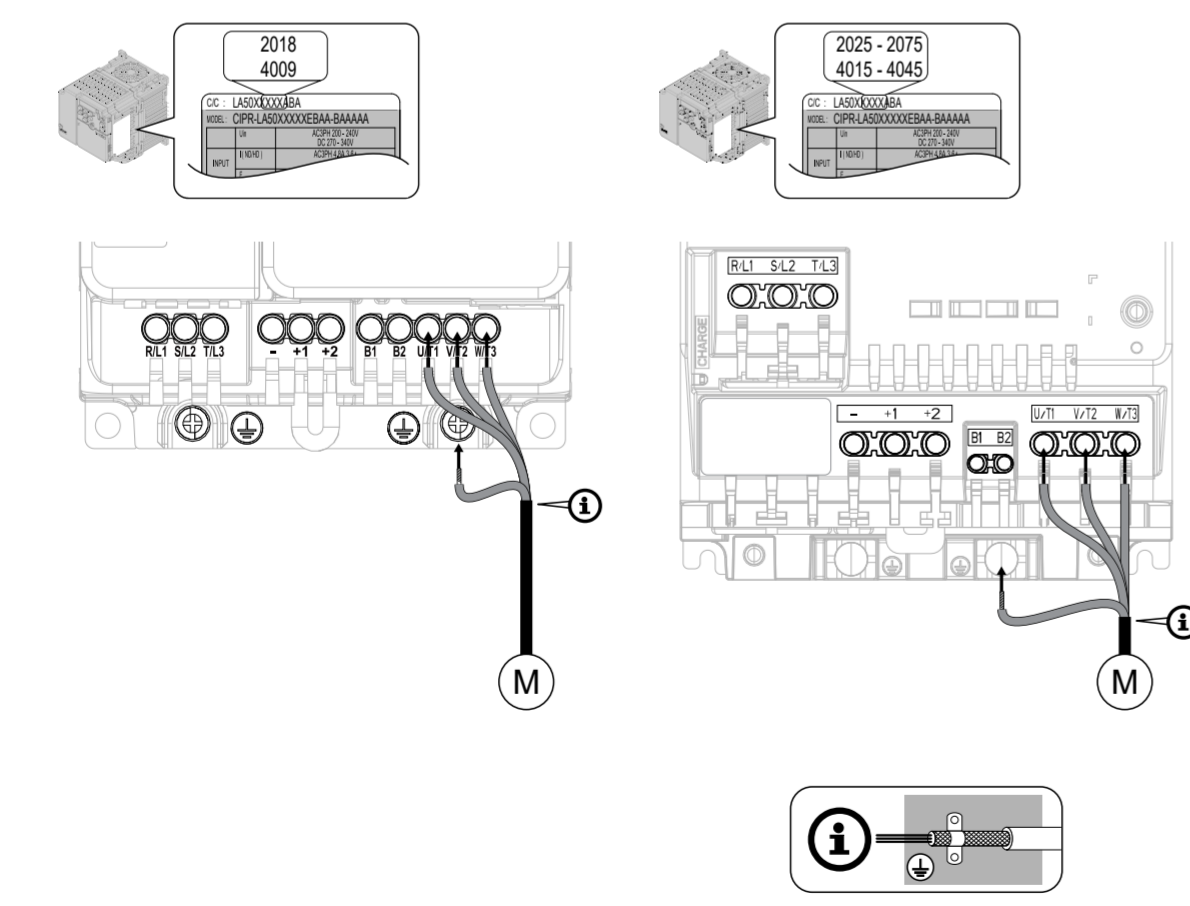

10

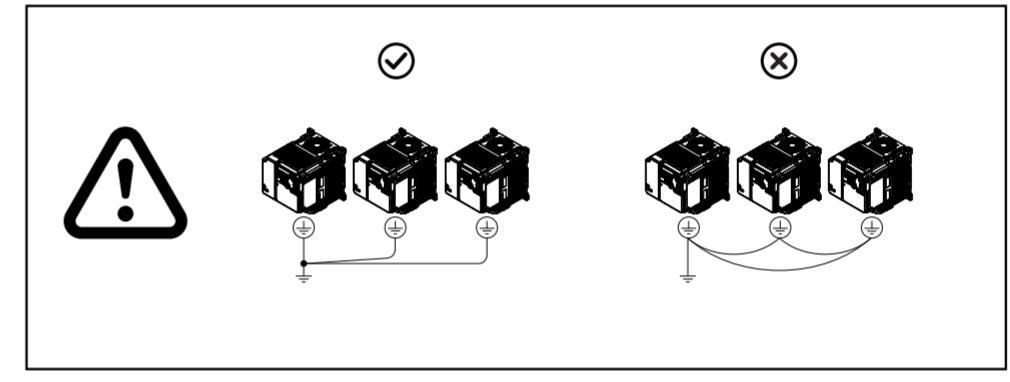
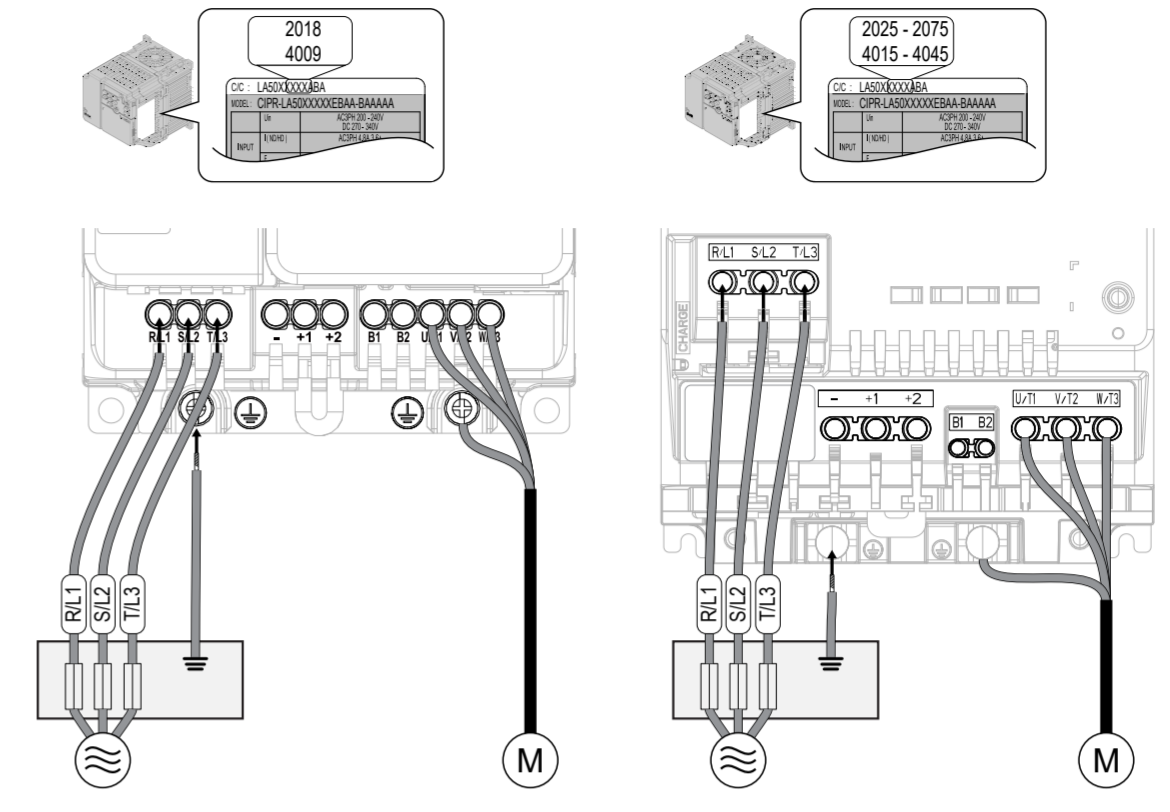

11

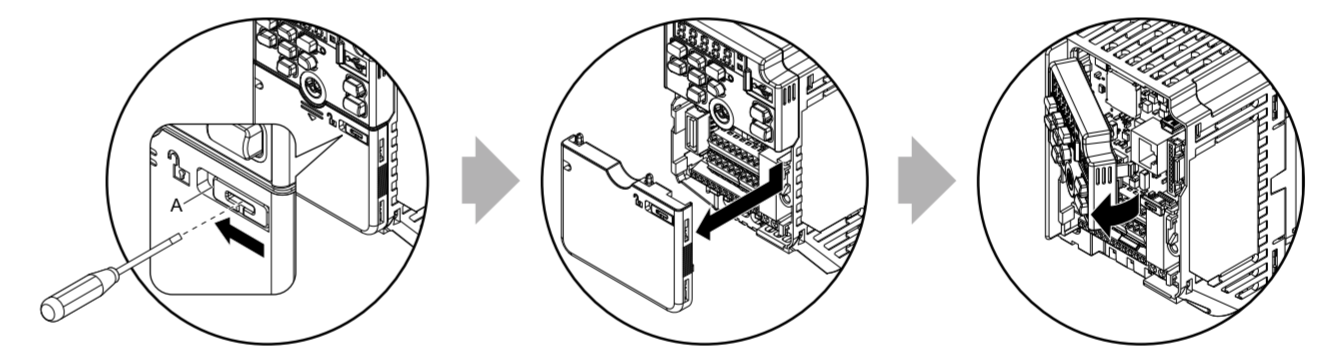

12

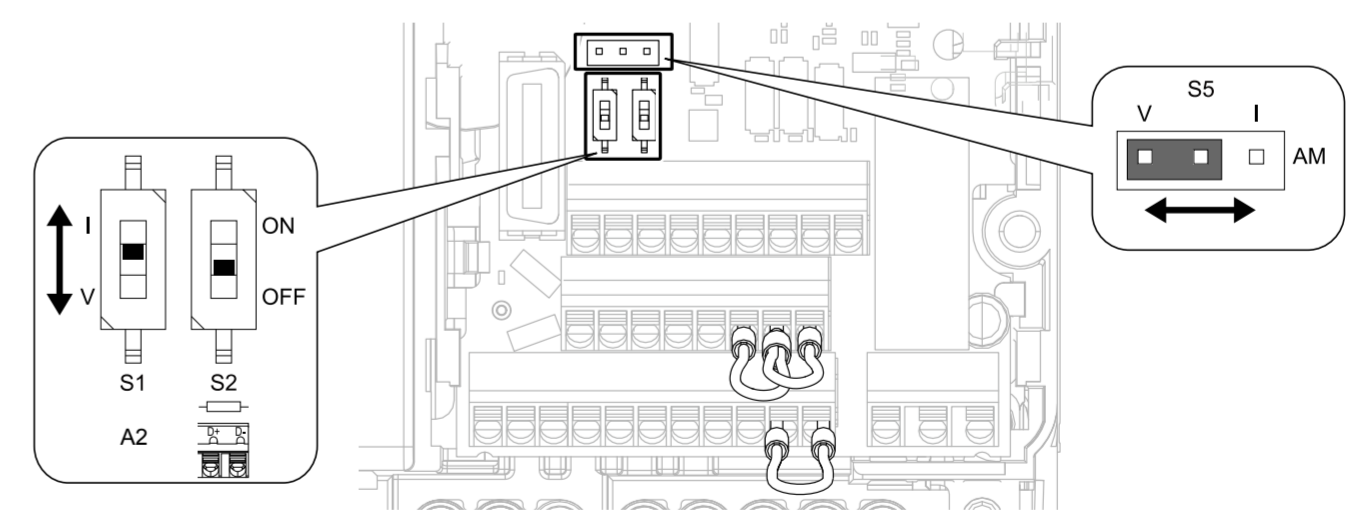

13

13

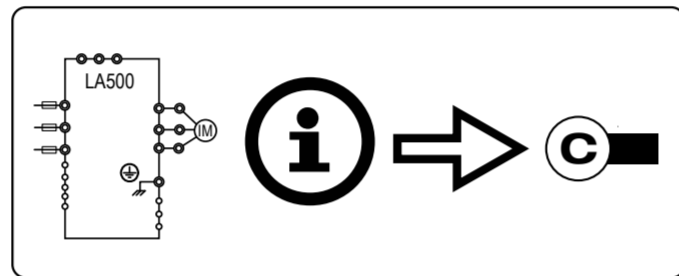
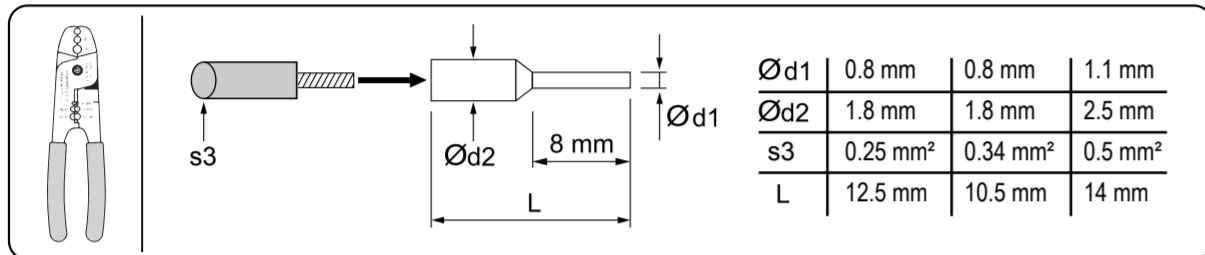
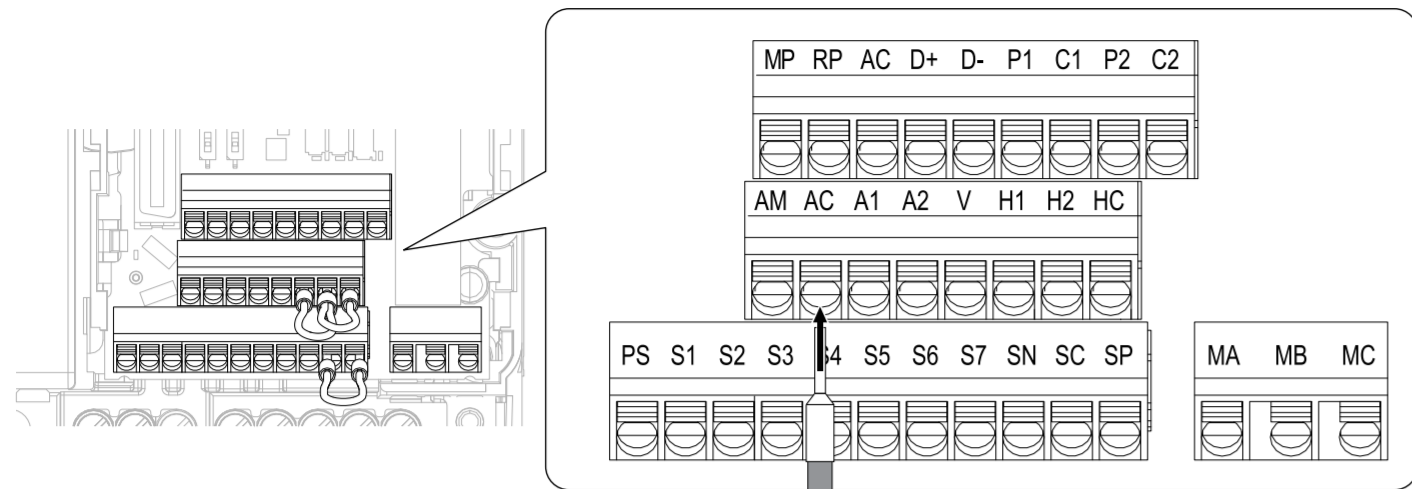

14

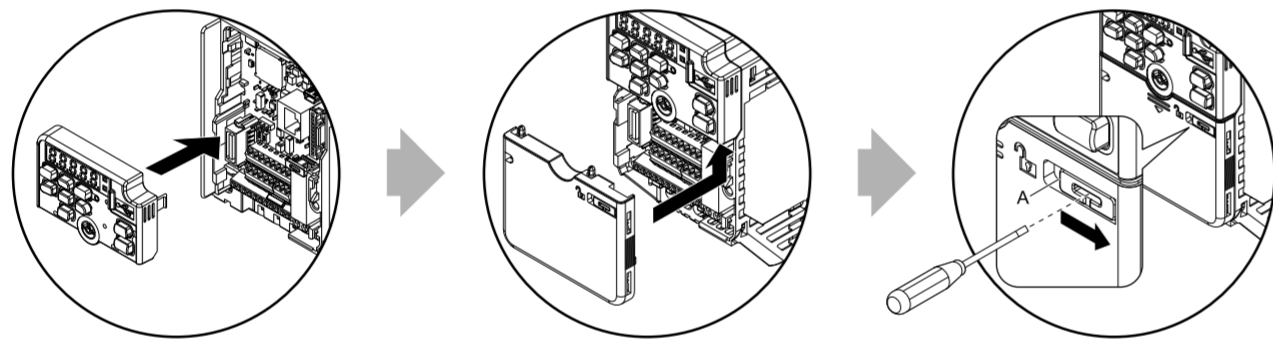

15

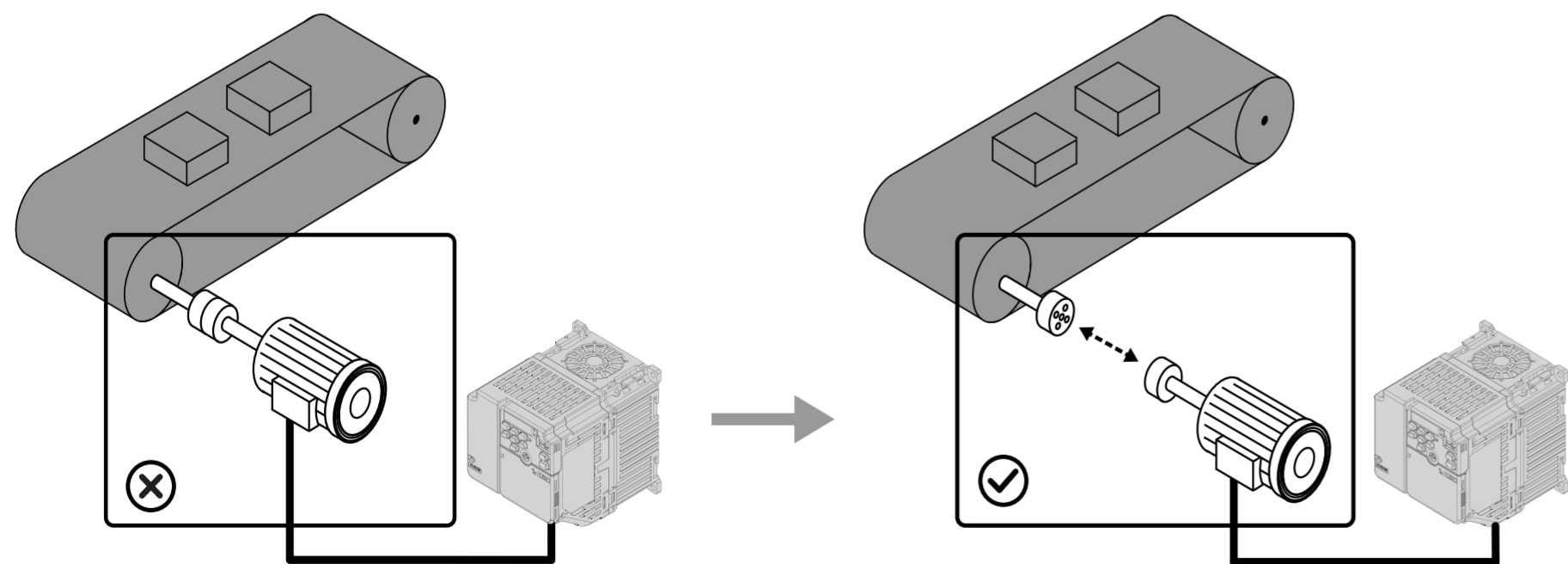

16

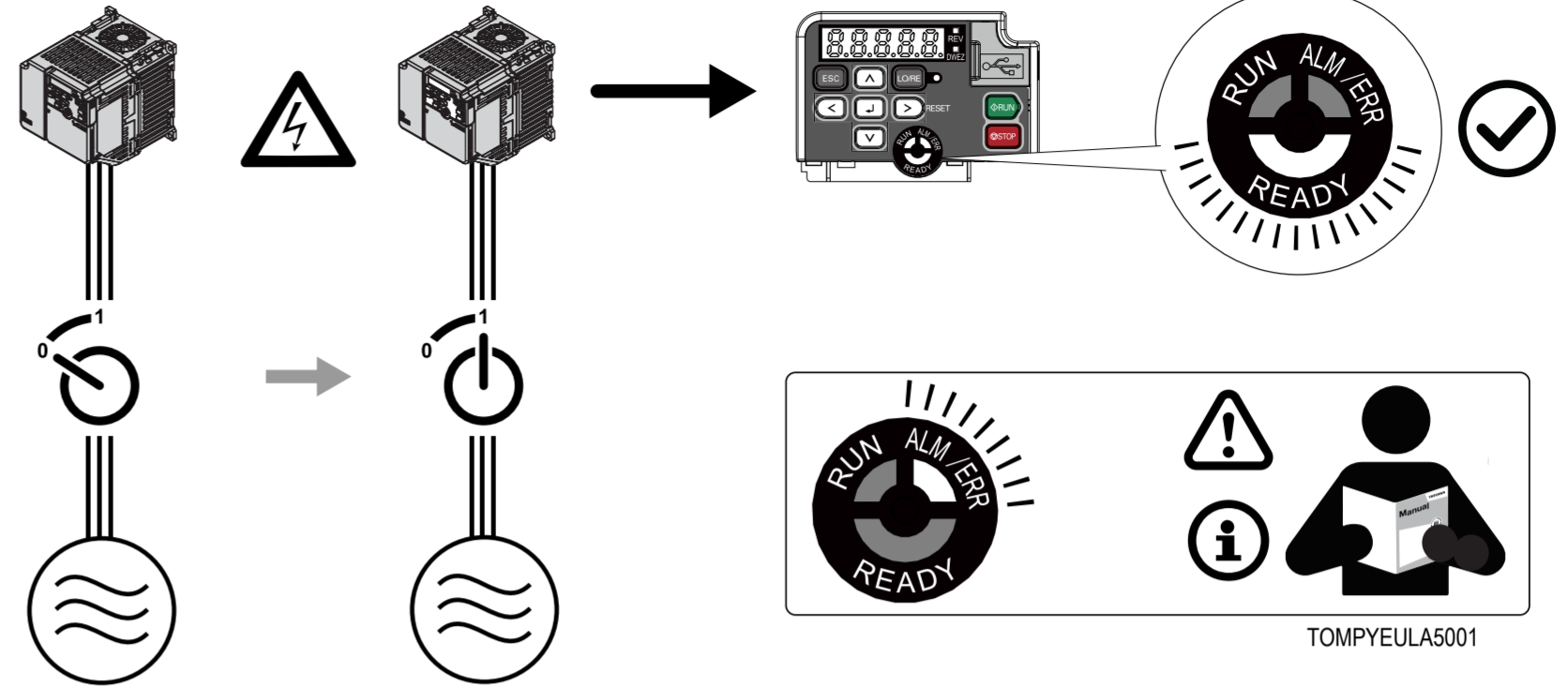

A

A: Initialization	E: Motor	n: Special Adjustment	S: Elevator Parameters
A1 Initialization	E1 V/f Pattern for Motor 1	n2 Auto Freq. Regulator (AFR)	S1 Brake Sequence
A2 User Parameters	E2 Motor 1 Parameters	n6 Online Tuning	S2 Slip Compensation for Elevators
b: Application	H: Terminal Functions	o: Keypad-Related Settings	S4 Rescue Operation
b1 Operation Mode Selection	H1 Digital Inputs	o1 Keypad Display	S6 Error Detection
b4 Timer Function	H2 Digital Outputs	o2 Keypad Operation	T: Motor Tuning
b6 Dwell Function	H4 Analog Outputs	o3 Copy Keypad Function	T1 Induction Motor Auto-Tuning
C: Tuning	L: Protection Functions	o4 Maintenance Monitors	U: Monitors
C1 Accel & Decel Time	L1 Motor Protection		U1 Operation Status Monitors
C2 S-Curve Characteristics	L2 Power Loss Ride Through		U2 Fault Trace
C3 Slip Compensation	L3 Stall Prevention		U3 Fault History
C4 Torque Compensation	L4 Speed Detection		U4 Maintenance Monitors
C6 Duty & Carrier Frequency	L5 Fault Restart		U6 Operation Status Monitors
d: Reference Settings	L6 Torque Detection		
d1 Frequency Reference	L7 Torque Limit		
	L8 Drive Protection		

B

Manual

PDF

WWW

<https://www.yaskawa.eu.com/manuals/la500>

YASKAWA  
DriveWizard Mobile

GET IT ON  
**Google Play**

Download on the  
**App Store**

C

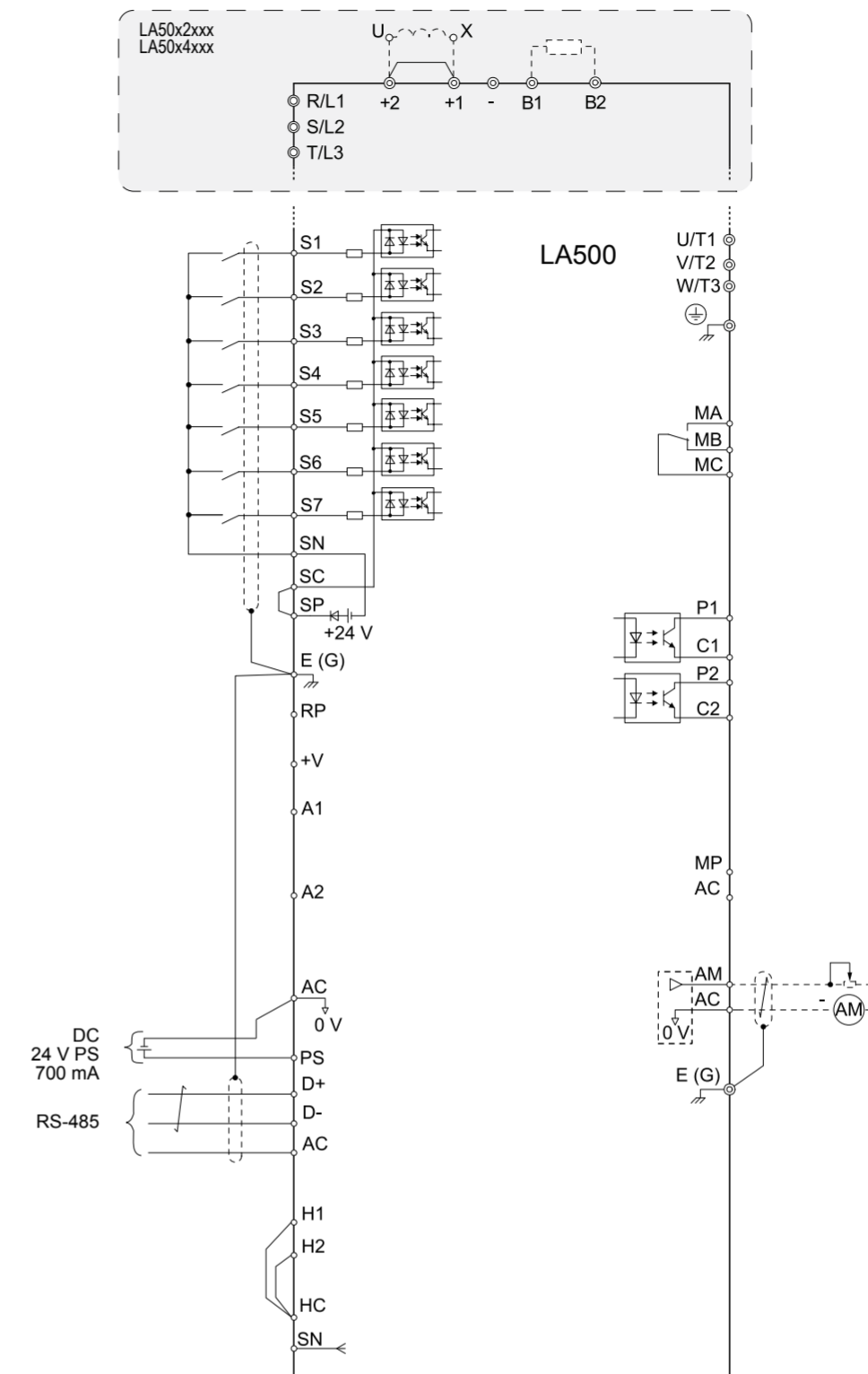

Terminal	Type	Signal Level	Default
S1	Multi-functional Digital Input 1 to 7	Photocoupler 24 V, 6 mA	Forward run/Stop
S2			Reverse run/Stop
S3			Nominal
S4			Inspection
S5			Relevelling
S6			Leveling
S7			Not used
SN	MFDI power 0 V	24 V, 150 mA	-
SC	MFDI common	With option card JOHB-PGX3-AE, max. 90 mA are available.	-
SP	MFDI power +24 VDC	-	-
H1	Safe Disable input 1	24 V, 6 mA	-
H2	Safe Disable input 1	Internal impedance: 4.7 kΩ	-
HC	Safe Disable function common	Minimum OFF time: 3 ms	-
RP	-	-	-
+V	Frequency setting power supply	10.5 V (20 mA maximum)	-
A1	-	-	-
A2	-	-	-
AC	Common	0 V	-
E(G)	Connect shielded cable	-	-
MA	Multi-Functional Digital Output	30 VDC, 10 mA ~ 1 A	Fault
MB	Output	250 VAC, 10 mA ~ 1 A	Fault
MC	Common	Minimum load: 5 V, 10 mA	-
P1	Multi-functional Photocoupler Output 1	48 VDC, 2 mA ~ 50 mA	During run
C1	Output 1		-
P2	Multi-functional Photocoupler Output 2	-	Speed agree 1
C2	Output 2	-	-
MP	-	-	-
AM	Analog Monitor Output	0 V ~ +10 V/0% ~ 100%	Output frequency
AC	Common	0 V	-
PS	External 24 V PS input	21.6 VDC ~ 26.4 VDC, 700 mA	-
AC	External 24 V PS ground	0 V	-
D+	-	-	-
D-	-	-	-
AC	Common	0 V	-